

768

Rev.
H

APPLICATION DRAWING

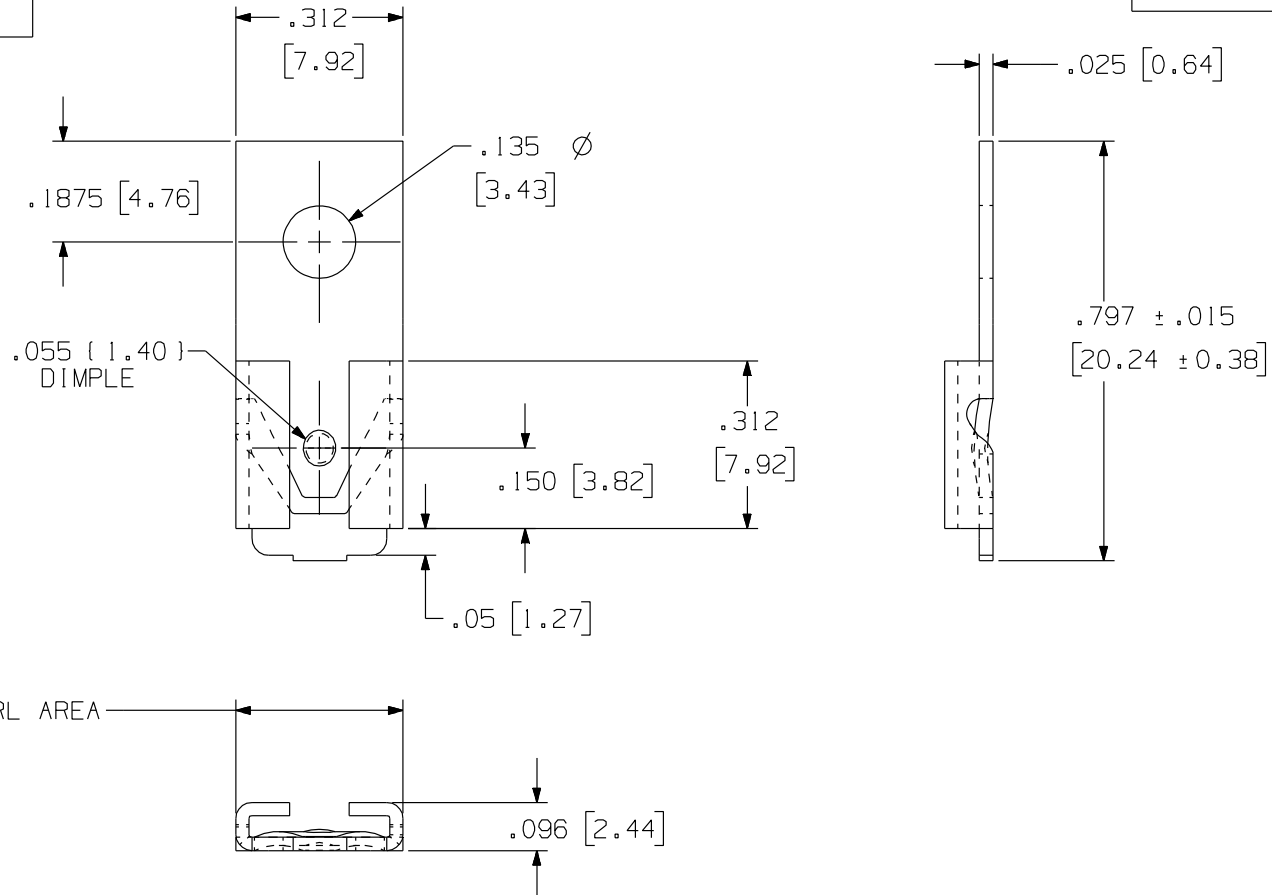

RoHS COMPLIANT

MATERIAL	FINISH
$.025$ (0.64) CDA 2600 BRASS	0.000150" (0.0038mm) 100% Tin over 0.00015" (0.0038mm) Copper

Zierick Product Related Recommendations are general guidelines only. Since each customer's design, process and application is different it is necessary that customers thoroughly test our products in specific applications.

ZIERICK

Radio Circle Drive
Mount Kisco, New York 10549

QUICK CONNECT

THIS DOCUMENT AND THE CONFIDENTIAL INFORMATION CONTAINED HERE ARE THE PROPERTY OF ZIERICK MANUFACTURING CORPORATION AND MAY NOT BE USED IN WHOLE OR IN PART IN ANY WAY, OR COMMUNICATED TO ANY PARTY OTHER THAN THE RECIPIENT WITHOUT THE EXPRESS PRIOR WRITTEN CONSENT OF ZIERICK MANUFACTURING CORPORATION.

768

H