

11B-XXX

Rev.

APPLICATION DRAWING

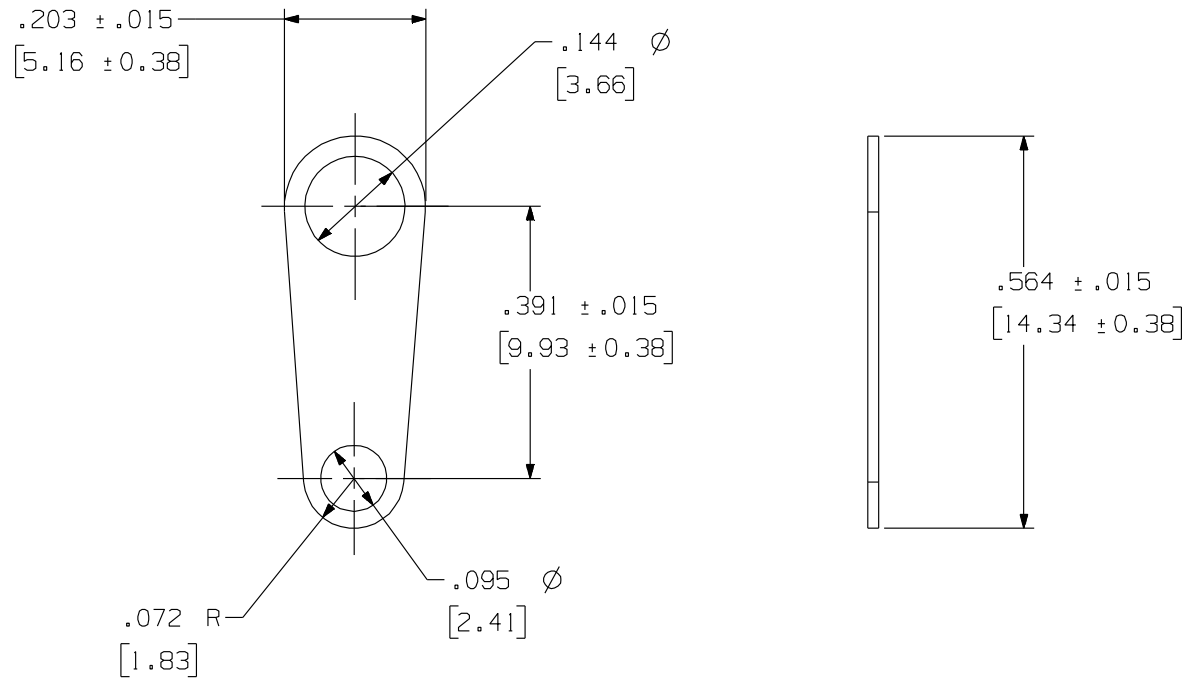

MATERIAL  
.016" (0.41mm) COPPER

PART NUMBER	"H"	FINISH
11B-120	.120" (3.05mm)	100% TIN OVER COPPER
11B-133	.133" (3.38mm)	100% TIN OVER COPPER
11B-144	.144" (3.66mm)	100% TIN OVER COPPER

Zierick Product Related Recommendations are general guidelines only. Since each customer's design, process and application is different it is necessary that customers thoroughly test our products in specific applications.

**ZIERICK**

Radio Circle Drive  
Mount Kisco, New York 10549

SOLDER TERMINAL

THIS DOCUMENT AND THE CONFIDENTIAL INFORMATION CONTAINED HERE ARE THE PROPERTY OF ZIERICK MANUFACTURING CORPORATION AND MAY NOT BE USED IN WHOLE OR IN PART IN ANY WAY, OR COMMUNICATED TO ANY PARTY OTHER THAN THE RECIPIENT WITHOUT THE EXPRESS PRIOR WRITTEN CONSENT OF ZIERICK MANUFACTURING CORPORATION.

11B-XXX