

Ring Terminals

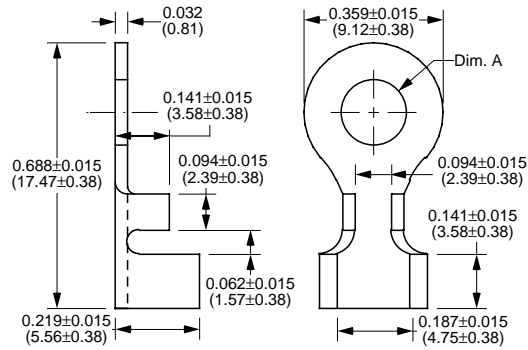

Part Number	Package Type	Material Type	Finish Code	Inventory Type	Dim. 'A'
5012-196-11	Reeled	Pre-Tinned Brass	11	Special	0.196" (4.98mm)

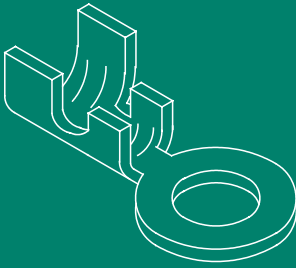
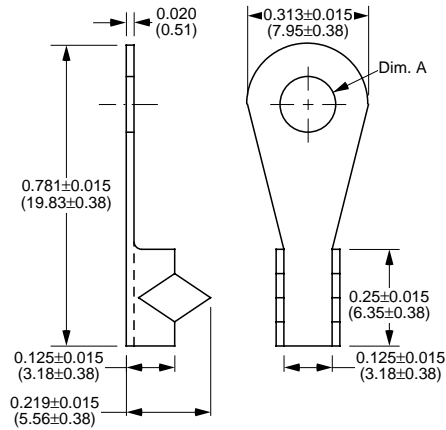
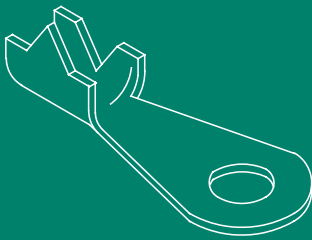

Part Number	Material Type	Finish Code	Inventory Type	Dim. 'A'
18-120-1	Brass	1	Special	0.120" (3.05mm)
18-130	Brass	0	Special	0.130" (3.30mm)
18-144	Brass	0	Special	0.144" (3.66mm)

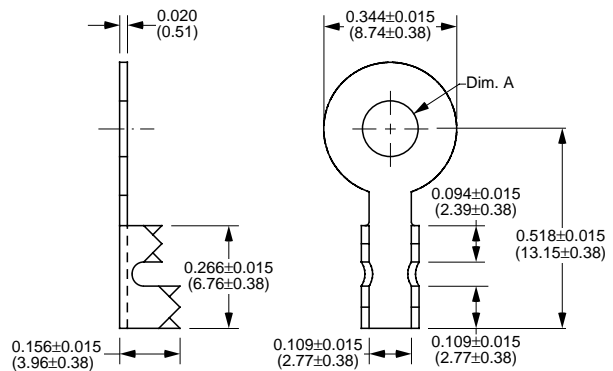
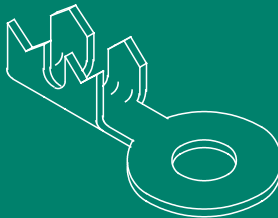

Part Number	Package Type	Material Type	Finish Code	Inventory Type	Dim. 'A'
28-144	Loose	Brass	0	Special	0.144" (3.66mm)
28-169	Loose	Brass	0	Special	0.169" (4.29mm)
28-196	Loose	Brass	0	Special	0.196" (4.98mm)