

928

Rev.

APPLICATION DRAWING

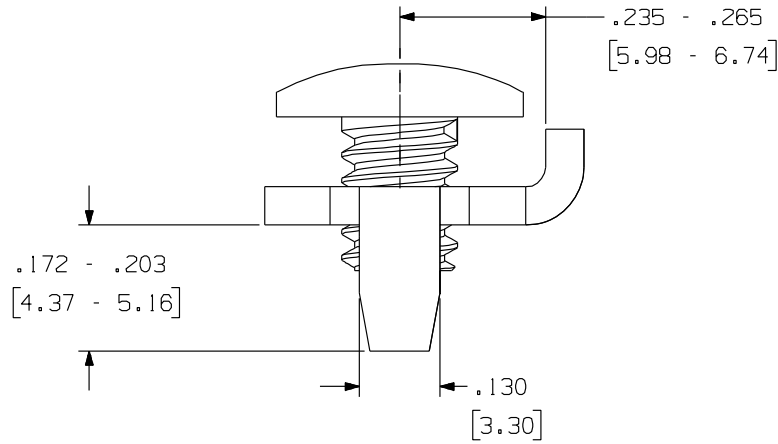
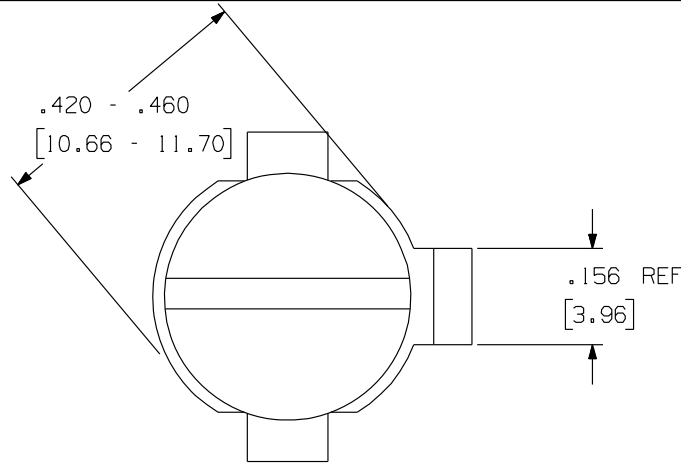
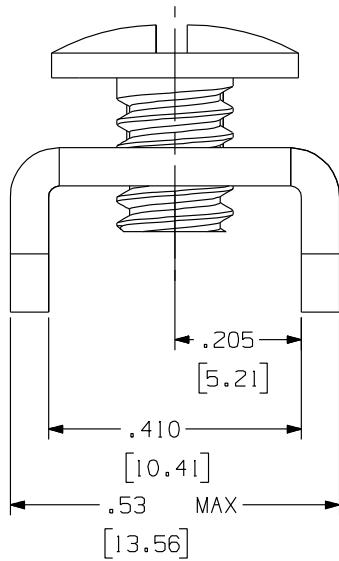

MATERIAL
.062 [1.57] BRASS

FINISH	SCREW TYPE	SCREW POSITION
100% TIN OVER COPPER	1/4 X 10-32 STAINLESS STEEL BINDING HEAD	INSERTED, STAKED, AND BACKED OUT

RoHS COMPLIANT

Zierick Product Related Recommendations are general guidelines only. Since each customer's design, process and application is different it is necessary that customers thoroughly test our products in specific applications.

ZIERICK

Radio Circle Drive
Mount Kisco, New York 10549

BINDING POST

THIS DOCUMENT AND THE CONFIDENTIAL INFORMATION CONTAINED HERE ARE THE PROPERTY OF ZIERICK MANUFACTURING CORPORATION AND MAY NOT BE USED IN WHOLE OR IN PART IN ANY WAY, OR COMMUNICATED TO ANY PARTY OTHER THAN THE RECIPIENT WITHOUT THE EXPRESS PRIOR WRITTEN CONSENT OF ZIERICK MANUFACTURING CORPORATION.

928