

349-XXX

Rev.  
C

APPLICATION DRAWING

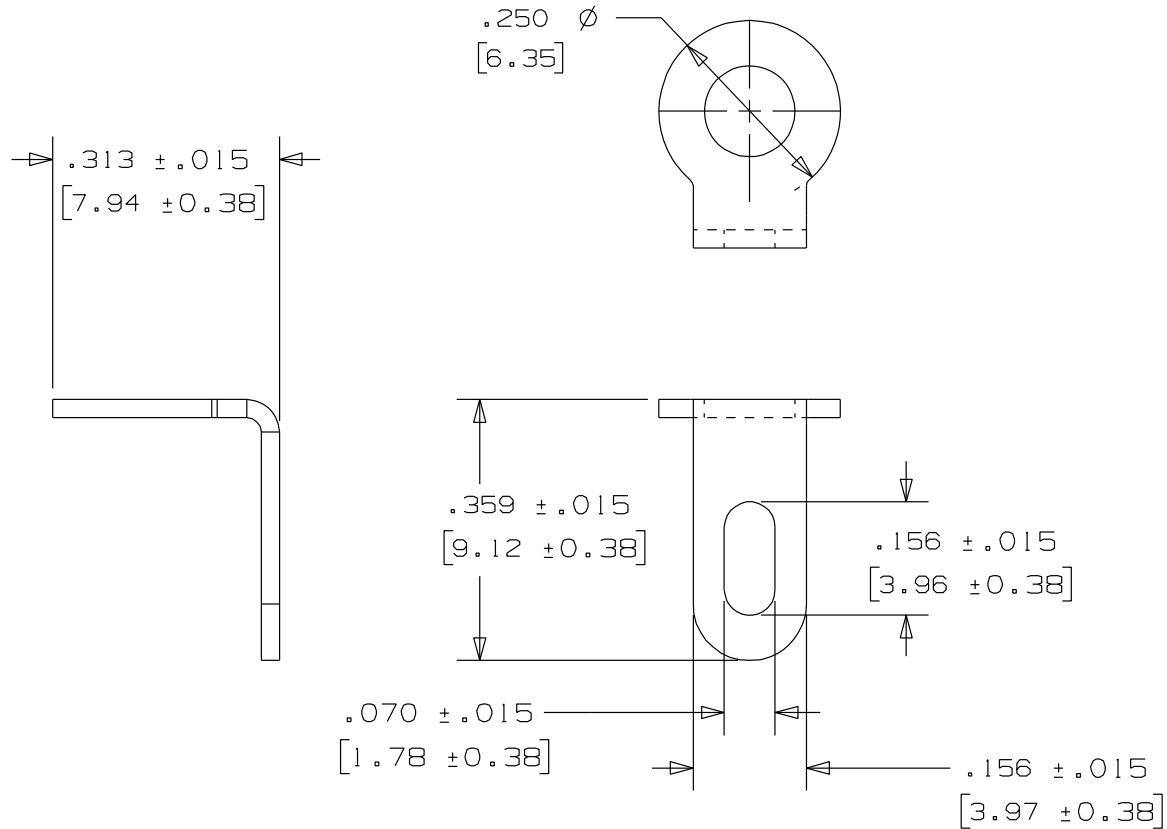
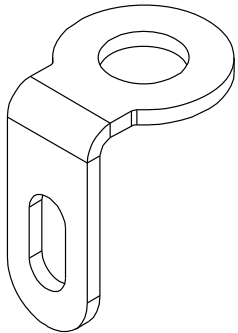

	PART NO.	"H"	FINISH
	349-125	.126" (3.18mm)	100% MATTE TIN OVER COPPER
MATERIAL	349-144	.144" (3.66mm)	100% MATTE TIN OVER COPPER
.025 (0.64mm) BRASS	349-156	.156" (3.96mm)	100% MATTE TIN OVER COPPER

Zierick Product Related Recommendations are general guidelines only. Since each customer's design, process and application is different it is necessary that customers thoroughly test our products in specific applications.

**ZIERICK**

Radio Circle Drive  
Mount Kisco, New York 10549

RIGHT ANGLE  
SOLDER TERMINAL

THIS DOCUMENT AND THE CONFIDENTIAL INFORMATION CONTAINED HERE ARE THE PROPERTY OF ZIERICK MANUFACTURING CORPORATION AND MAY NOT BE USED IN WHOLE OR IN PART IN ANY WAY, OR COMMUNICATED TO ANY PARTY OTHER THAN THE RECIPIENT WITHOUT THE EXPRESS PRIOR WRITTEN CONSENT OF ZIERICK MANUFACTURING CORPORATION.

349-XXX

C