

255-130

Rev.  
K

APPLICATION DRAWING

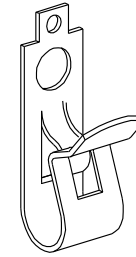
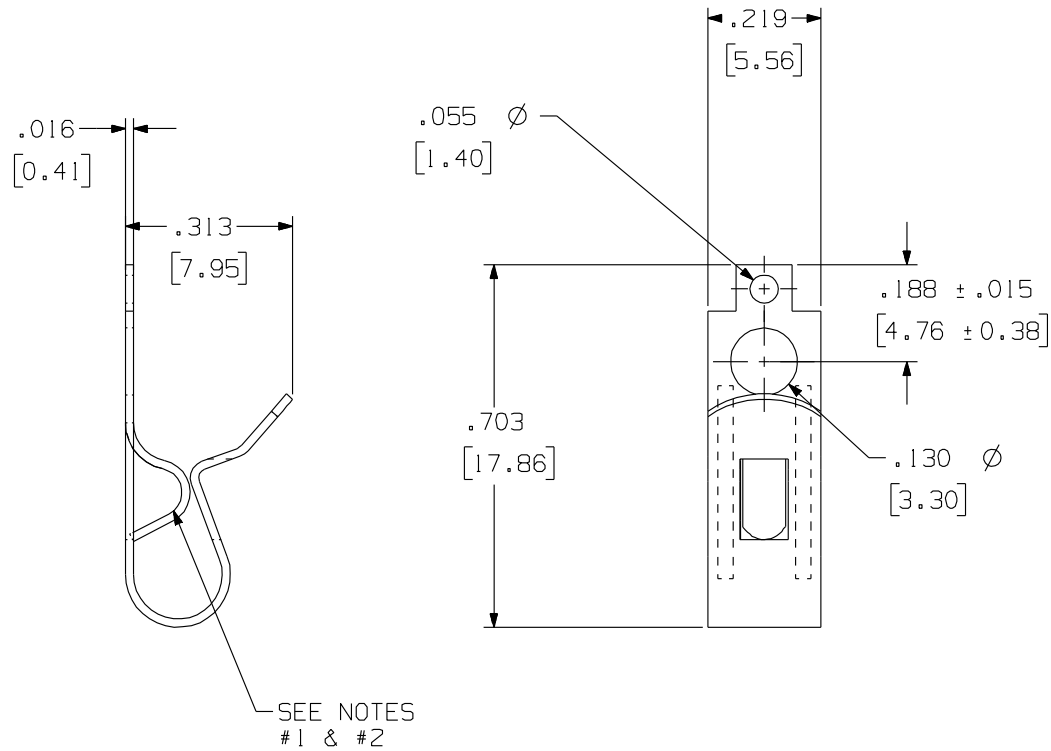

SCALE 2:1

NOTE:

1. .WHEN SPRING IS COMPRESSED AN Ø.093 DIAMETER PIN SHOULD PUSH THROUGH.
2. WHEN SPRING IS RELAXED AN .016 PIN SHOULD BE HELD IN PLACE.

PART No.	MATERIAL	FINISH
255-130	.016 [0.41] BRASS	100 % MATT TIN
255-130-9	.016 [0.41] BRASS	PLAIN

Zierick Product Related Recommendations are general guidelines only. Since each customer's design, process and application is different it is necessary that customers thoroughly test our products in specific applications.

**ZIERICK**

Radio Circle Drive  
Mount Kisco, New York 10549

SPRING CLIP

THIS DOCUMENT AND THE CONFIDENTIAL INFORMATION CONTAINED HERE ARE THE PROPERTY OF ZIERICK MANUFACTURING CORPORATION AND MAY NOT BE USED IN WHOLE OR IN PART IN ANY WAY, OR COMMUNICATED TO ANY PARTY OTHER THAN THE RECIPIENT WITHOUT THE EXPRESS PRIOR WRITTEN CONSENT OF ZIERICK MANUFACTURING CORPORATION.

255-130

K