

Recommended Solder Pad Geometry

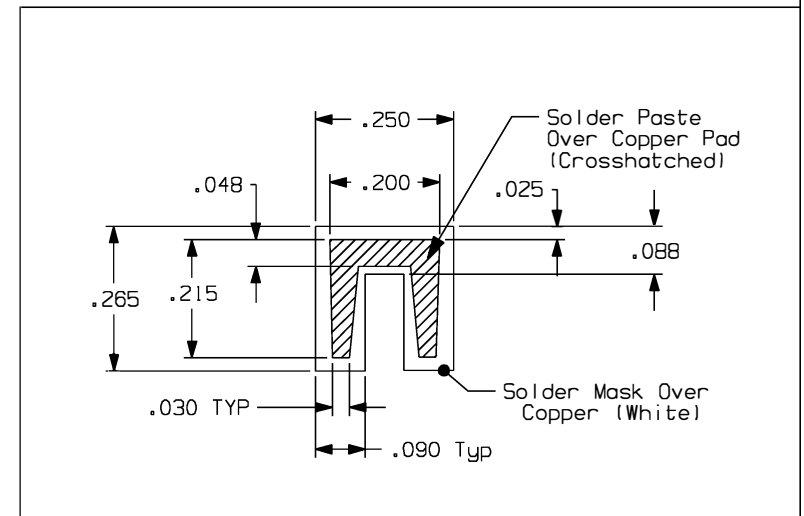

MATERIAL: .016 BRASS  
FINISH: 100% TIN OVER COPPER

RoHS COMPLIANT

Zierick Product Related Recommendations are general guidelines only. Since each customer's design, process and application is different it is necessary that customers thoroughly test our products in specific applications.



Radio Circle Drive  
Mount Kisco, New York 10549

SMT UNIVERSAL TAB RECEPTACLE  
TOP ENTRY

THIS DOCUMENT AND THE CONFIDENTIAL INFORMATION CONTAINED HERE ARE THE PROPERTY OF ZIERICK MANUFACTURING CORPORATION AND MAY NOT BE USED IN WHOLE OR IN PART IN ANY WAY, OR COMMUNICATED TO ANY PARTY OTHER THAN THE RECIPIENT WITHOUT THE EXPRESS PRIOR WRITTEN CONSENT OF ZIERICK MANUFACTURING CORPORATION.