

**-- PRELIMINARY --  
NOT RELEASED FOR PRODUCTION**

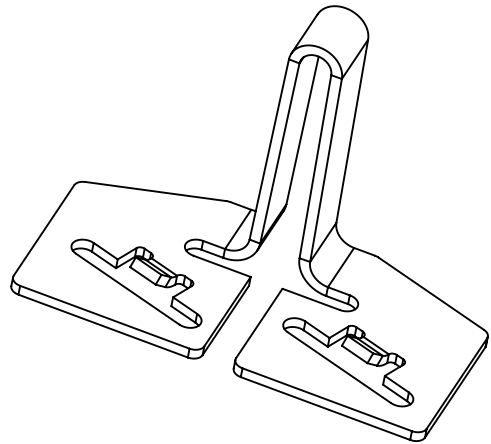
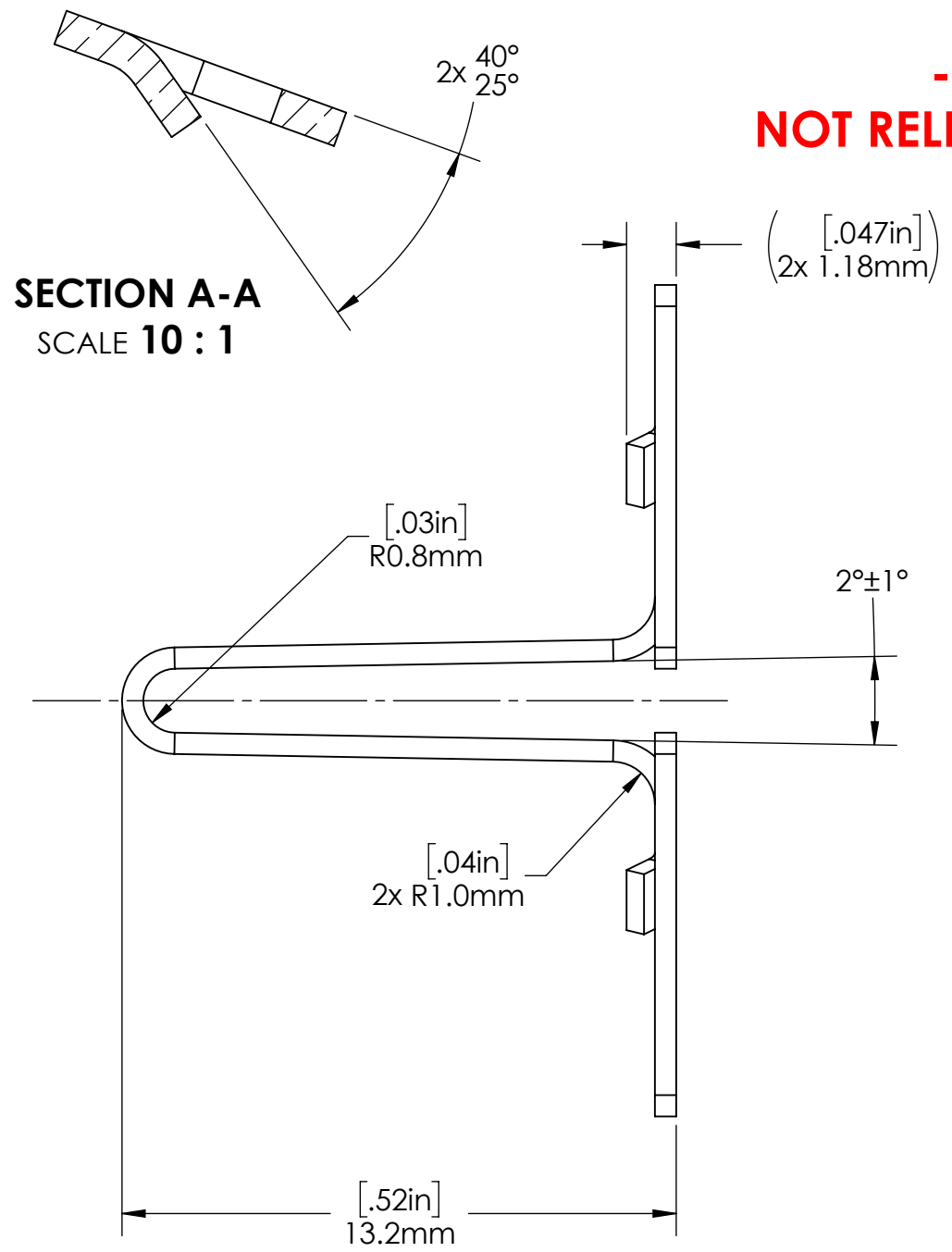
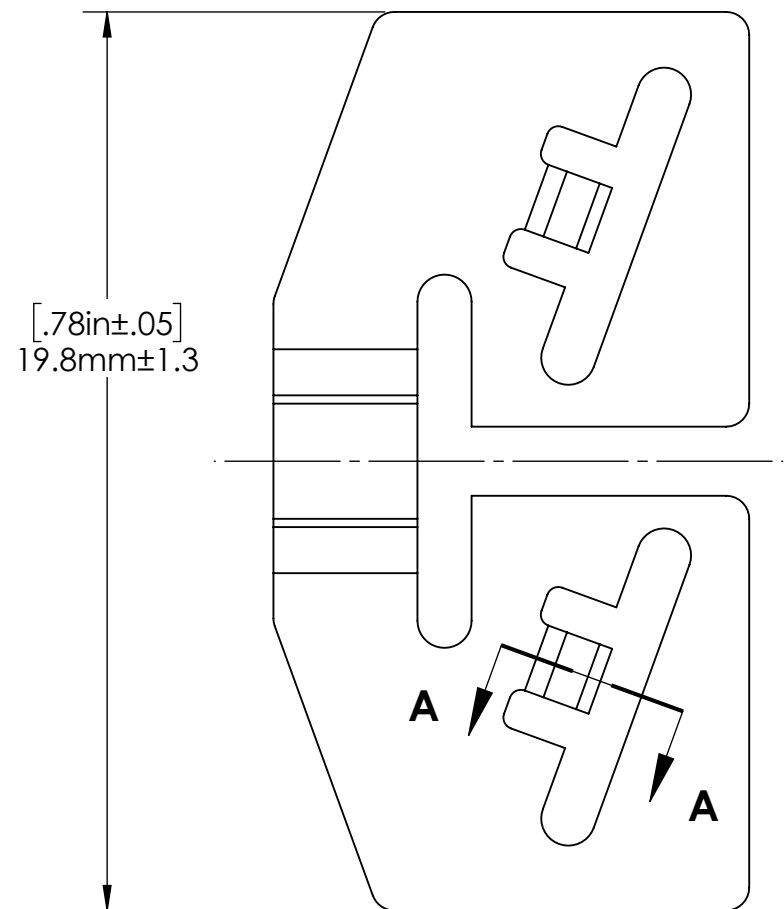

**-- PRELIMINARY --  
NOT RELEASED FOR PRODUCTION**

- NOTES:
1. MATERIAL: PHOSPHOR BRONZE, 24 GAGE (.0201 INCH) SPRING TEMPER, GRADE A, #8 HARD. NICKEL PLATED .0001 in (.0025mm) THICK.
  2. PART TO BE FREE OF BURRS AND SHARP EDGES.
  3. UNSPECIFIED FILLETS AND RADII TO BE R0.13mm [.005 in].
  4. RoHS AND REACH COMPLIANT.
  5. SEE SHEET 2 FOR FLAT LAYOUT.
  6. ATTACHES TO 6.35 x 0.81mm (.25 x .032 INCH) MALE QUICK-CONNECT.

★ = KEY CHARACTERISTICS

REV	DESCRIPTION	BY	DATE	ECN
01	PRELIMINARY RELEASE	SSL	7/7/22	N/A
REVISIONS				

UNLESS OTHERWISE SPECIFIED: DIMENSIONS ARE IN MILLIMETERS TOLERANCES: X mm (Fraction) +/-0.8mm (.031") X.X mm (0.XX") +/-0.5mm (.020") X.XXmm (0.XXX") +/- 0.25mm (.010) ANGLES +/- 1° INTERPRET GEOMETRIC TOLERANCING PER ASME Y14.5 - 2009 MATERIAL SEE NOTES FINISH SEE NOTES		THE INFORMATION CONTAINED IN THIS DRAWING IS THE SOLE PROPERTY OF MASTER APPLIANCE, INC. ANY REPRODUCTION IN PART OR AS A WHOLE WITHOUT THE WRITTEN PERMISSION OF MASTER APPLIANCE, INC. IS PROHIBITED.			
DRAWN BY	SSL	6/29/22	TITLE:		
CHECKED BY			SIZE	DWG. NO.	REV
			<b>B</b>	<b>50134</b>	<b>01</b>
DO NOT SCALE DRAWING			SCALE: 5:1	WEIGHT: -	SHEET 1 OF 2

**-- PRELIMINARY --  
NOT RELEASED FOR PRODUCTION**

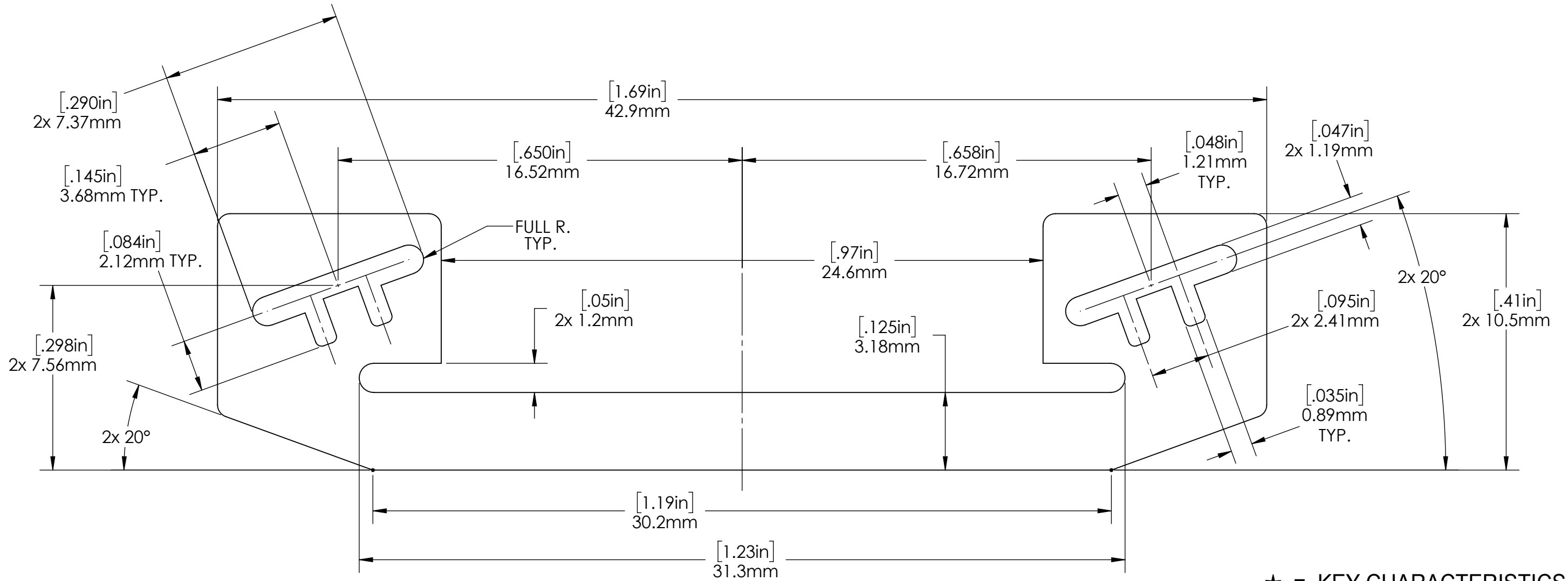
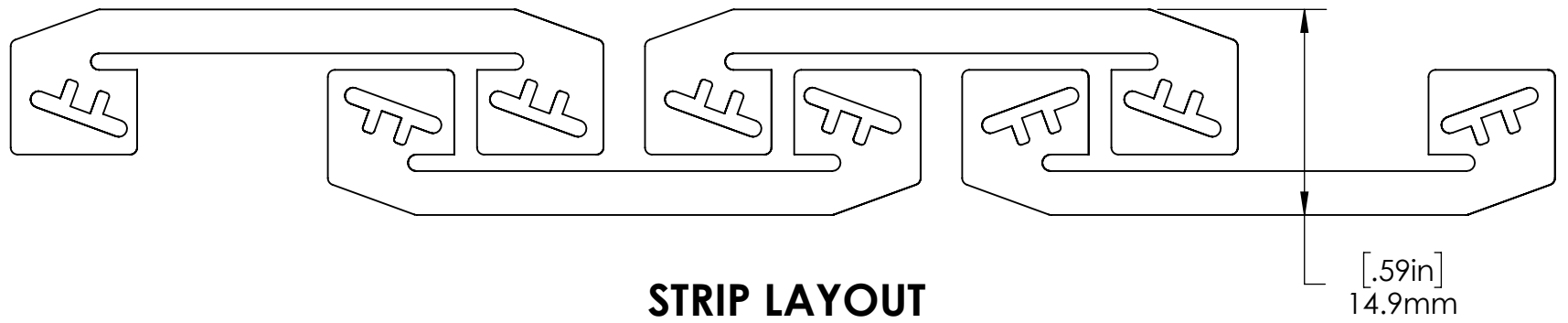

**-- PRELIMINARY --  
NOT RELEASED FOR PRODUCTION**

★ = KEY CHARACTERISTICS

UNLESS OTHERWISE SPECIFIED: DIMENSIONS ARE IN MILLIMETERS TOLERANCES: X mm (Fraction) +/-0.8mm (.031") X.X mm (0.XX") +/-0.5mm (.020") X.XXmm (0.XXX") +/- 0.25mm (.010)		THE INFORMATION CONTAINED IN THIS DRAWING IS THE SOLE PROPERTY OF MASTER APPLIANCE, INC. ANY REPRODUCTION IN PART OR AS A WHOLE WITHOUT THE WRITTEN PERMISSION OF MASTER APPLIANCE, INC. IS PROHIBITED.		<b>MASTER</b> HEAT TOOLS FOR INDUSTRY™	
ANGLES +/- 1°		DRAWN BY	SSL	6/29/22	TITLE: JUMPER BRACKET ROCKER SWITCH, OPT HG
INTERPRET GEOMETRIC TOLERANCING PER ASME Y14.5 - 2009		CHECKED BY			SIZE DWG. NO. REV <b>B</b> 50134 01
MATERIAL SEE NOTES		DO NOT SCALE DRAWING		SCALE: 1:1	WEIGHT: -
FINISH SEE NOTES				SHEET 2 OF 2	

REV	DESCRIPTION	BY	DATE	ECN
-	See Sheet1	-	-	-
REVISIONS				