

APPLICATION USED ON
NEXT ASSY. N.A. EA992-2141

PURCHASE FROM:
ZIERICK MFG. CORP.
NEW ROCHELLE N.Y. #193
CODE IDENT. # 79963

249013

SYD.	DESCRIPTION	DATE	APPROVAL
-	REDRAWN, NO CHANGE R.L.	10-28-60	V.C.
A	ADDED MAT. TO MAT. BOX	9/1/63	C.P.
B	ADDED NONE TO FINISH BOX		
B	MATL. WAS "COPPER HOT TIN DIP", 2. FIN. WAS "NONE"	6-27	HF
C	ECO 07778, CL II (1) REV MATL (2) BLOCK (3) REV TITLE (3) CODE IDENT WAS 36536	85/12/27	BS
C1	ECO 14812	88/11/10	JK

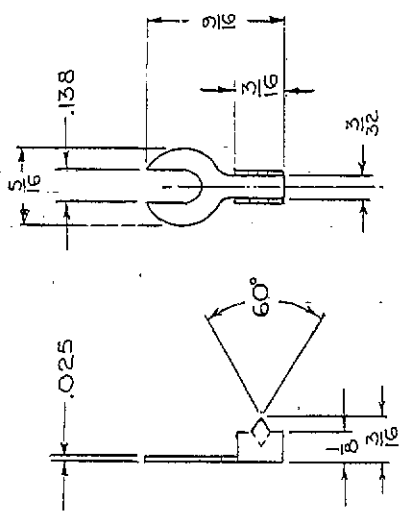

SPECIFICATION CONTROL DRAWING 16-1

TITLE		SIGNATURE & DATE	
LUG, TERMINAL		R.H. G-24-60	
DR.	V.C. 6-24-60	CHK.	V.C. 6-24-60
CHK. DR.	V.S. 6-24-60	M.E.	P.P. 6-24-60
E.E.	NA	APPD.	P.PAN 6-24-60

UNLESS OTHERWISE SPECIFIED DIMENSIONS ARE IN INCHES
FRACTIONS DECIMALS ON ANGLES
± 1/64 ± .005 ± 0°30'

MATERIAL QQ-C-576
COLD ROLLED SOFT ANNEALED COPPER
FINISH ELECTRO-PLATE PER MIL-10127-TYPE II
ALL SCREW THREADS PER N.B.S. #28

CLASSIFICATION OF CHARACTERISTICS
CLASSED AS MINOR B UNLESS SPECIFIED
CRITICAL MAJOR MINOR A

SIMMONDS PRODUCTION PRODUCTS, INC.
VERGENNES, VT
DWG. NO. 249013
CODE IDENT 89305
SHEET